

JIS

JAPANESE
INDUSTRIAL
STANDARD

Translated and Published by
Japanese Standards Association

JIS B 2808 : 2005

(JSMA/JSA)

Spring pins

ICS 21.060.50

Reference number : JIS B 2808 : 2005 (E)

Foreword

This translation has been made based on the original Japanese Industrial Standard revised by the Minister of Economy, Trade and Industry through deliberations at the Japanese Industrial Standards Committee as the result of proposal for revision of Japanese Industrial Standard submitted by Japan Spring Manufacturers Association (JSMA)/Japanese Standards Association (JSA) with the draft being attached, based on the provision of Article 12 Clause 1 of the Industrial Standardization Law applicable to the case of revision by the provision of Article 14.

Consequently **JIS B 2808 : 1999** is replaced with this Standard.

This revision has been made based on **ISO 8748 : 1997 Spring-type straight pins—Coiled, heavy duty**, **ISO 8749 : 1986 Pins and grooved pins—Shear test**, **ISO 8750 : 1997 Spring-type straight pins—Coiled, standard duty**, **ISO 8751 : 1997 Spring-type straight pins—Coiled, light duty**, **ISO 8752 : 1997 Spring-type straight pins—Slotted, heavy duty** and **ISO 13337 : 1997 Spring-type straight pins—Slotted, light duty** for the purposes of making it easier to compare this Standard with International Standard; to prepare Japanese Industrial Standard conforming with International Standard; and to propose a draft of an International Standard which is based on Japanese Industrial Standard.

Attention is drawn to the possibility that some parts of this Standard may conflict with a patent right, application for a patent after opening to the public, utility model right or application for registration of utility model after opening to the public which have technical properties. The relevant Minister and the Japanese Industrial Standards Committee are not responsible for identifying the patent right, application for a patent after opening to the public, utility model right or application for registration of utility model after opening to the public which have the said technical properties.

Date of Establishment: 1966-01-01

Date of Revision: 2005-07-20

Date of Public Notice in Official Gazette: 2005-07-20

Investigated by: Japanese Industrial Standards Committee
Standards Board

Technical Committee on Machine Elements

JIS B 2808 : 2005, First English edition published in 2006-03

Translated and published by: Japanese Standards Association
4-1-24, Akasaka, Minato-ku, Tokyo, 107-8440 JAPAN

In the event of any doubts arising as to the contents,
the original JIS is to be the final authority.

© JSA 2006

All rights reserved. Unless otherwise specified, no part of this publication may be reproduced or utilized in any form or by any means, electronic or mechanical, including photocopying and microfilm, without permission in writing from the publisher.

Printed in Japan

FM/AT

Contents

	Page
Introduction	1
1 Scope	1
2 Normative references	1
3 Classification	2
4 Shapes and dimensions	2
4.1 Shapes and dimensions of spring pins	2
4.2 Ends of spring pins	3
5 Application	3
6 Quality	3
7 Test methods	6
7.1 Hardness test	6
7.2 Shear strength test	6
8 Designation of products	7
9 Marking	7
10 Acceptance inspection	7
Annex (informative) Comparison table between JIS and corresponding International Standards	14

Spring pins

Introduction This Japanese Industrial Standard has been prepared based on the second edition of **ISO 8748** *Spring-type straight pins—Coiled, heavy duty* published in 1997, the second edition of **ISO 8750** *Spring-type straight pins—Coiled, standard duty* published in 1997, the second edition of **ISO 8751** *Spring-type straight pins—Coiled, light duty* published in 1997, the second edition of **ISO 8752** *Spring-type straight pins—Slotted, heavy duty* published in 1997 and the first edition of **ISO 13337** *Spring-type straight pins—Slotted, light duty* published in 1997 with some modifications of the technical contents. Further, the first edition of **ISO 8749** *Pins and grooved pins—Shear test* published in 1986 has been wholly adopted in “7.2 Shear test” of this Standard with some changes made of the technical contents.

The portions given sidelines or dotted underlines are the matters modified from the original International Standards. A list of modifications with the explanations is given in Annex (informative)

1 Scope This Standard specifies the characteristics of heavy duty and light duty slotted spring pins and heavy duty, standard duty and light duty coiled spring pins made of steel or of austenitic or martensitic stainless steel (hereafter referred to as “spring pins”).

Remarks : The International Standards corresponding to this Standard are as follows.

In addition, symbols which denote the degree of correspondence in the contents between the relevant International Standards and JIS are IDT (identical), MOD (modified), and NEQ (not equivalent) according to **ISO/IEC Guide 21**.

ISO 8748:1997 *Spring-type straight pins—Coiled, heavy duty* (MOD)

ISO 8749:1986 *Pins and grooved pins—Shear test* (MOD)

ISO 8750:1997 *Spring-type straight pins—Coiled, standard duty* (MOD)

ISO 8751:1997 *Spring-type straight pins—Coiled, light duty* (MOD)

ISO 8752:1997 *Spring-type straight pins—Slotted, heavy duty* (MOD)

ISO 13337:1997 *Spring-type straight pins—Slotted, light duty* (MOD)

2 Normative references The following standards contain provisions which, through reference in this text, constitute provisions of this Standard. The most recent editions (including amendments) of the standards indicated below shall be applied.

JIS B 0401-1 *ISO system of limits and fits—Part 1: Bases of tolerances, deviations and fits*

Remarks : **ISO 286-1:1988** *ISO system of limits and fits—Part 1: Bases of tolerances, deviations and fits* is identical with the said standard.

JIS B 1044 *Fasteners—Electroplated coatings*

Remarks : ISO 4042:1999 *Fasteners—Electroplated coatings* is identical with the said standard.

JIS B 1091 *Fasteners—Acceptance inspection*

Remarks : ISO 3269:2000 *Fasteners—Acceptance inspection* is identical with the said standard.

JIS Z 2244 *Vickers hardness test—Test method*

Remarks : ISO 6507-1:1997 *Metallic materials—Vickers hardness test—Part 1: Test method* is equivalent to the said standard.

3 Classification Spring pins are classified into 6 types according to plate thickness as given in table 1.

Table 1 Classification of spring pins

	Type	Symbol	Dimensions
Slotted	Heavy duty	GH	Attached table 1
	Standard duty	GS	Attached table 2
	Light duty	GL	Attached table 3
Coiled	Heavy duty	CH	Attached table 4
	Standard duty	CS	Attached table 5
	Light duty	CL	Attached table 6

4 Shapes and dimensions

4.1 Shapes and dimensions of spring pins The shapes and dimensions of spring pins shall be in accordance with figures 1 and 2 and attached tables 1 to 5.

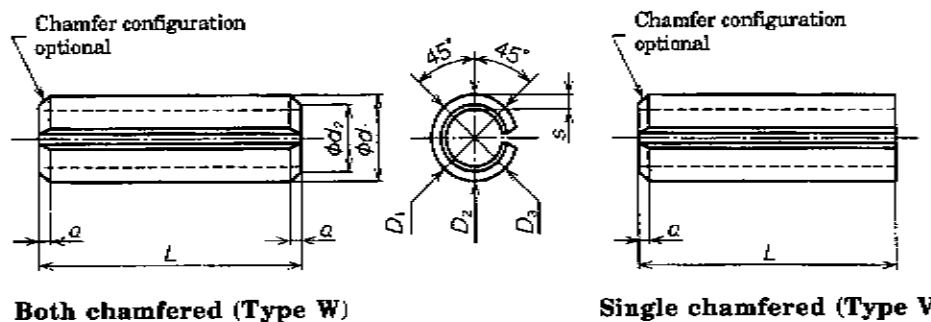

Remarks : The maximum of d_1 shall be the maximum value on the circumference of the pin, and the minimum of d_1 shall be the mean value of D_1 , D_2 and D_3 .

Figure 1 Shape of slotted spring pin

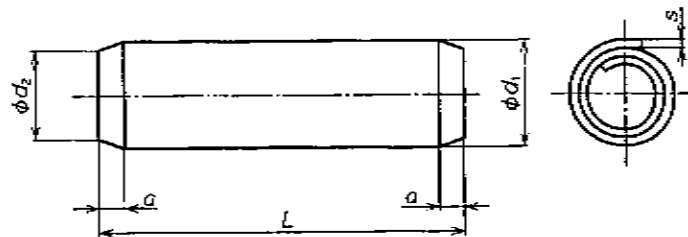

Figure 2 Shape of coiled spring pin

4.2 Ends of spring pins The ends of spring pins shall be in accordance with either of the two chamfer types as given in table 2.

Table 2 Ends of spring pins⁽¹⁾

Type	Type symbol
Both chamfered	W
Single chamfered	V

Note (1) For those 10 mm or greater in nominal diameter, the single chamfered end may be chosen by agreement between the purchaser and the manufacturer.

Remarks : Spring pins with a shape and width of slot which guarantee no interlocking are referred to as N type pins. See table 3 for the detailed specification.

5 Application The diameter of the hole into which the spring pin is to be inserted shall be equal to the nominal diameter d_1 of the mating pin and match the tolerance class H12 (see JIS B 0401-1). When mounted in the smallest permitted hole the slot shall not fully close.

6 Quality The quality of spring pins shall be in accordance with tables 3 and 4.

Table 3 Quality requirements for slotted spring pins

Material ⁽²⁾	Steel		Austenitic stainless steel	Martensitic stainless steel
Material symbol	St		A	C
Chemical composition (%)	Steel (St) at the supplier's discretion, either:		C ≤ 0.15 Mn ≤ 2.00 Si ≤ 1.50 Cr 16 to 20 Ni 6 to 12 P ≤ 0.045 S ≤ 0.03 Mo ≤ 0.8	C ≥ 0.15 Mn ≤ 1.00 Si ≤ 1.00 Cr 11.5 to 14 Ni ≤ 1.00 P ≤ 0.04 S ≤ 0.03
	Carbon steel	Silicon manganese steel		
	For light duty C ≥ 0.64 Mn ≥ 0.6	C ≥ 0.5 Si ≥ 1.5 Mn ≥ 0.7		
	For heavy duty C ≥ 0.65 Mn ≥ 0.5			
Hardness	Hardened and tempered or austempered to a Vickers hardness of 420 HV30 to 520 HV30	Hardened and tempered to a Vickers hardness of 420 HV30 to 520 HV30	Cold worked	Hardened and tempered to a Vickers hardness of 440 HV30 to 560 HV30
Slot	Normal case	Form and width of slot at the discretion of the supplier.		
	Type N	Non-interlocking pins with a form and/or width of slot which guarantees no interlocking may be supplied by special agreement between the purchaser and the manufacturer.		
Surface finish	Spring pins made of carbon steel and silicon manganese steel shall be supplied without surface treatment, but treated with a protective lubricant, unless otherwise specified by agreement between customer and supplier. If pins are surface coated appropriate plating or coating processes should be employed to avoid hydrogen embrittlement. When pins are electroplated or phosphate-coated, they shall be suitably treated immediately after plating or coating to obviate detrimental hydrogen embrittlement. ⁽³⁾ All tolerances shall apply prior to the application of a plating or coating.		Plain, i.e. pins to be supplied in natural finish.	
Surface condition	Pins shall have a smooth surface. No detrimental defects such as burrs shall appear on any part of the pin.			
Shear strength test	The test shall be in accordance with clause 7 and 1 mm to 25 mm of spring pins shall satisfy the shear strength requirement in attached tables 1 to 3.			

Notes ⁽²⁾ Other materials as agreed between the purchaser and the manufacturer.

⁽³⁾ The prevention of hydrogen embrittlement shall be carried out in accordance with JIS B 1044 under the conditions agreed between the purchaser and the manufacturer.

Table 4 Quality requirements for coiled spring pins

Material ⁽⁴⁾	Steel		Austenitic stainless steel	Martensitic stainless steel
Material symbol	St		A	C
Chemical composition (%)	All pin diameters	Alternative for pin diameters $d_1 \geq 12$ mm	C ≤ 0.15 Mn ≤ 2.00 Si ≤ 1.50 Cr 16 to 19 P ≤ 0.045 S ≤ 0.03 Mo ≤ 0.8	C ≥ 0.15 Mn ≤ 1.00 Si ≤ 1.00 Cr 11.5 to 14 Ni ≤ 1.00 P ≤ 0.04 S ≤ 0.03
	C ≥ 0.64 Mn ≥ 0.6 Si ≥ 0.15 Cr ⁽⁵⁾ P ≤ 0.04 S ≤ 0.05	C ≥ 0.38 Mn ≥ 0.70 Si ≥ 0.20 Cr ≥ 0.80 V ≥ 0.15 P ≤ 0.035 S ≤ 0.04		
Hardness	Hardened and tempered to a Vickers hardness of 420 HV30 to 520 HV30		Cold worked	Hardened and tempered to a Vickers hardness of 440 HV30 to 560 HV30
Surface finish	Spring pins shall be supplied without surface treatment, but treated with a protective lubricant, unless otherwise specified by agreement between the customer and the supplier. If pins are surface coated appropriate plating or coating processes should be employed to avoid hydrogen embrittlement. When pins are electroplated or phosphate-coated, they shall be suitably treated immediately after plating or coating to obviate detrimental hydrogen embrittlement ⁽⁶⁾ . All tolerances shall apply prior to the application of a plating or coating.		Plain, i.e. pins to supplied in natural finish.	
Surface condition	Pins shall have a smooth surface. No detrimental defects such as burrs shall appear on any part of the pin.			
Shear strength test	The test shall be in accordance with clause 7 and the spring pins shall satisfy the shear strength requirement in attached tables 4 to 6.			

Notes (4) Other materials as agreed between the purchaser and the manufacturer.

(5) Use of Cr is optional.

(6) The prevention of hydrogen embrittlement shall be carried out in accordance with **JIS B 1044** under the conditions agreed between the purchaser and the manufacturer.

7 Test methods

7.1 Hardness test The hardness test shall be in accordance with the method specified in JIS Z 2244 or any method equivalent to this.

7.2 Shear strength test The shear test consists of subjecting a pin to a shear load using a suitable test fixture in figure 3 and recording the maximum load to fracture. The pin support members and the member for applying the load shall have holes with diameters conforming to the nominal pin size (tolerance H6) and a hardness of not less than 700 HV.

The clearance between the supporting member and the load member shall not exceed 0.15 mm. The shear planes shall be at least one pin diameter away from each end and at least two diameters apart. Pins too short to be tested by double shear shall be tested by shearing two pins simultaneously in a single shear.

Spring pins shall be mounted in the test fixture with the slot upwards.

Pins shall be tested to fracture. The maximum load applied to the pin coincident with or prior to pin fracture shall be regarded as the shear strength of the pin.

The speed of testing shall not exceed 13 mm/min.

Spring pins 25 mm or greater in nominal diameter shall be tested in accordance with figure 3 or as agreed between the purchaser and the manufacturer.

However, the shear strength in attached tables shall be satisfied.

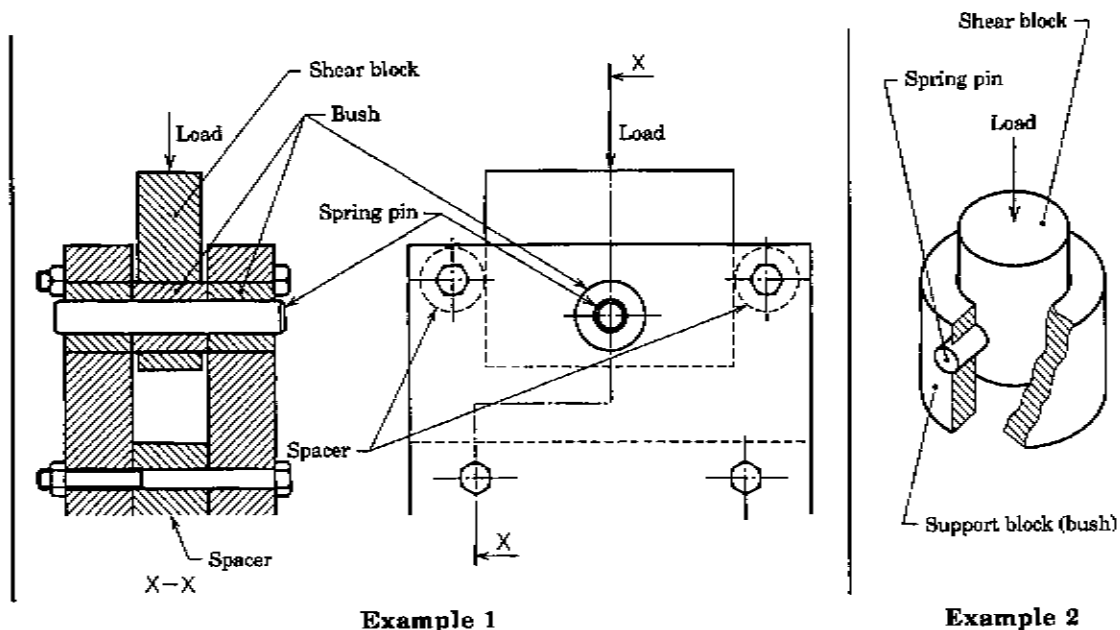

Figure 3 Typical pin shear test fixture

Remarks : The thickness of the shear block in Example 1 and the diameter of the shear block in Example 2 shall be approximately 1/3 the length of the pin being tested.

8 Designation of products Spring pins shall be designated by the number of this Standard, nominal diameter, length, type, type symbol representing the end chamfer and material symbol.

Example 1 A steel (St) light duty slotted spring pin, with nominal diameter 6 mm, length 30 mm, both chamfered:

JIS B 2808 - 6 × 30 - GL - W - St
 (Number or (nominal (type) (type of end (material)
 name of this diameter) (type of end
 Standard) × (length) chamfer)

Example 2 An austenitic stainless steel (A) standard duty slotted spring pin, with nominal diameter 8 mm, length 30 mm, non-interlocking (N type), single chamfered:

JIS B 2808 - 8 × 30 - GS - N - V - A
 (Number or (nominal (type) (non- (type of end (material)
 name of this diameter) (type of end
 Standard) × (length) interlocking) chamfer)

Example 3 A steel (St) light duty coiled spring pin, with nominal diameter 6 mm, length 30 mm, both chamfered:

JIS B 2808 - 6 × 30 - CL - W - St
 (Number or (nominal (type) (type of end (material)
 name of this diameter) (type of end
 Standard) × (length) chamfer)

9 Marking On the package of spring pins, the following information shall be clearly marked with tags or other suitable methods.

- a) Reference to this Standard
- b) Nominal diameter × length
- c) Type
- d) Type symbol of the end chamfer
- e) Name of material or its symbol
- f) Volume
- g) Serial number
- h) Name of manufacturer

10 Acceptance inspection The acceptance inspection shall be in accordance with JIS B 1091.

Attached Table 2 Slotted, for standard duty

Unit: mm

Nominal diameter		1	1.2	1.4	1.5	1.6	2	2.5	3	4	5	6	8	10	13	
Mounting diameter d_1	Max.	1.2	1.4	1.6	1.7	1.8	2.25	2.75	3.25	4.4	5.4	6.4	8.6	10.6	13.7	
	Min.	1.1	1.3	1.5	1.6	1.7	2.15	2.65	3.15	4.2	5.2	6.2	8.3	10.3	13.4	
Thickness s		0.2	0.25	0.28	0.3	0.3	0.4	0.5	0.6	0.8	1	1.2	1.6	2	2.5	
Chamfer diameter d_2		Max.	0.9	1.1	1.3	1.4	1.5	1.9	2.4	2.9	3.9	4.8	5.8	7.8	9.8	12.7
Shear load kN (min.)		0.69	1.02	1.35	1.55	1.68	2.76	4.31	6.2	10.8	17.25	24.83	44.13	68.94	112.78	
Applicable hole (ref.)	Diameter	1	1.2	1.4	1.5	1.6	2	2.5	3	4	5	6	8	10	13	
	Tolerance	+ 0.08					+ 0.09			+ 0.12			+ 0.15		+ 0.2	
Length L	Tolerance	0														
4	+ 0.5 0	○	○	○	○	○										
5		○	○	○	○	○	○	○								
6		○	○	○	○	○	○	○	○							
8		○	○	○	○	○	○	○	○	○						
10		○	○	○	○	○	○	○	○	○	○					
12	+ 1 0		○	○	○	○	○	○	○	○	○	○				
14				○	○	○	○	○	○	○	○	○				
16						○	○	○	○	○	○	○	○			
18							○	○	○	○	○	○	○	○		
20								○	○	○	○	○	○	○	○	
22									○	○	○	○	○	○	○	○
25										○	○	○	○	○	○	○
28											○	○	○	○	○	○
32												○	○	○	○	○
36													○	○	○	○
40													○	○	○	
45														○	○	
50															○	
56	+ 1.5 0														○	○
63																○
70																○
80																○
90																○
100																○
110																○
125																○
140																○

Remarks: Lengths inside the bold lines are recommended.

Attached Table 4 Coiled, for heavy duty

Unit: mm

Nominal diameter		1.5	2	2.5	3	3.5	4	5	6	8	10	12	14	16	20
Before mounting d_1	Min.	1.61	2.11	2.62	3.12	3.64	4.15	5.15	6.18	8.25	10.3	12.35	14.4	16.4	20.4
	Max.	1.71	2.21	2.73	3.25	3.79	4.3	5.35	6.4	8.55	10.65	12.75	14.85	16.9	21
Before mounting d_2 (ref.)		1.4	1.9	2.4	2.9	3.4	3.9	4.85	5.85	7.8	9.75	11.7	13.6	15.6	19.6
Chamfer c		0.5	0.7	0.7	0.9	1	1.1	1.3	1.5	2	2.5	3	3.5	4	4.5
Thickness e		0.17	0.22	0.28	0.33	0.39	0.45	0.56	0.67	0.9	1.1	1.3	1.6	1.8	2.2
Shear strength ⁽¹⁾ KN (min.)		1.9	3.5	5.5	7.6	10	13.5	20	30	53	84	120	165	210	340
F_s ⁽²⁾		1.45	2.5	3.8	5.7	7.6	10	15.5	23	41	64	91			
L ⁽²⁾															
Length	Min.	Max.													
4	3.75	4.25	○	○											
5	4.75	5.25	○	○	○										
6	5.75	6.25	○	○	○	○	○								
8	7.75	8.25	○	○	○	○	○	○							
10	9.75	10.25	○	○	○	○	○	○	○						
12	11.5	12.5	○	○	○	○	○	○	○	○					
14	13.5	14.5	○	○	○	○	○	○	○	○					
16	15.5	16.5	○	○	○	○	○	○	○	○	○				
18	17.5	18.5	○	○	○	○	○	○	○	○	○	○			
20	19.5	20.5	○	○	○	○	○	○	○	○	○	○	○		
22	21.5	22.5	○	○	○	○	○	○	○	○	○	○	○	○	
24	23.5	24.5	○	○	○	○	○	○	○	○	○	○	○	○	○
26	25.5	26.5	○	○	○	○	○	○	○	○	○	○	○	○	○
28	27.5	28.5		○	○	○	○	○	○	○	○	○	○	○	○
30	29.5	30.5		○	○	○	○	○	○	○	○	○	○	○	○
32	31.5	32.5		○	○	○	○	○	○	○	○	○	○	○	○
35	34.5	35.5		○	○	○	○	○	○	○	○	○	○	○	○
40	39.5	40.5		○	○	○	○	○	○	○	○	○	○	○	○
45	44.5	45.5			○	○	○	○	○	○	○	○	○	○	○
50	49.5	50.5				○	○	○	○	○	○	○	○	○	○
55	54.25	55.75						○	○	○	○	○	○	○	○
60	59.25	60.75							○	○	○	○	○	○	○
65	64.25	65.75								○	○	○	○	○	○
70	69.25	70.75									○	○	○	○	○
75	74.25	75.75										○	○	○	○
80	79.25	80.75											○	○	○
85	84.25	85.75												○	○
90	89.25	90.75													○
95	94.25	95.75													
100	99.25	100.75													
120	119.25	120.75													
140	139.25	140.75													
160	159.25	160.75													
180	179.25	180.75													
200	199.25	200.75													

Notes (1) Applies to steel and martensitic stainless steel products.

(2) Lengths above 200 mm shall be subject to the agreement between the purchaser and the manufacturer.

Remarks: Lengths inside the bold lines are recommended.



Attached Table 5 Coiled, for standard duty

Unit: mm

Nominal diameter		0.8	1	1.2	1.5	2	2.5	3	3.5	4	5	6	8	10	12	14	16	20
Before mounting d_1	Min.	0.85	1.05	1.25	1.62	2.13	2.65	3.15	3.67	4.2	5.25	6.25	8.3	10.35	12.4	14.45	16.45	20
	Max.	0.91	1.15	1.35	1.73	2.25	2.78	3.3	3.84	4.4	5.5	6.5	8.63	10.8	12.85	14.95	17	21
Before mounting d_2 (ref.)		0.75	0.95	1.15	1.4	1.9	2.4	2.9	3.4	3.9	4.85	5.85	7.8	9.75	11.7	13.6	15.6	19
Chamfer a		0.3	0.3	0.4	0.5	0.7	0.7	0.9	1	1.1	1.3	1.5	2	2.5	3	3.5	4	4
Thickness t		0.07	0.08	0.1	0.13	0.17	0.21	0.25	0.29	0.33	0.42	0.5	0.67	0.84	1	1.2	1.3	1
Shear strength ⁽¹³⁾ kN (min.)		0.4	0.6	0.9	1.45	2.5	3.9	5.5	7.5	9.6	15	22	39	62	89	120	155	250
L ⁽¹⁴⁾																		
Length	Min.																	
	Max.																	
4	3.75	4.25	○	○	○	○	○											
5	4.75	5.25	○	○	○	○	○	○										
6	5.75	6.25	○	○	○	○	○	○	○									
8	7.75	8.25	○	○	○	○	○	○	○	○								
10	9.75	10.25	○	○	○	○	○	○	○	○	○							
12	11.5	12.5	○	○	○	○	○	○	○	○	○	○						
14	13.5	14.5	○	○	○	○	○	○	○	○	○	○	○					
16	15.5	16.5	○	○	○	○	○	○	○	○	○	○	○	○				
18	17.5	18.5				○	○	○	○	○	○	○	○	○				
20	19.5	20.5				○	○	○	○	○	○	○	○	○	○			
22	21.5	22.5				○	○	○	○	○	○	○	○	○	○			
24	23.5	24.5				○	○	○	○	○	○	○	○	○	○	○		
26	25.5	26.5					○	○	○	○	○	○	○	○	○	○		
28	27.5	28.5					○	○	○	○	○	○	○	○	○	○	○	
30	29.5	30.5					○	○	○	○	○	○	○	○	○	○	○	
32	31.5	32.5					○	○	○	○	○	○	○	○	○	○	○	○
35	34.5	35.5					○	○	○	○	○	○	○	○	○	○	○	○
40	39.5	40.5					○	○	○	○	○	○	○	○	○	○	○	○
45	44.5	45.5						○	○	○	○	○	○	○	○	○	○	○
50	49.5	50.5							○	○	○	○	○	○	○	○	○	○
55	54.25	55.75								○	○	○	○	○	○	○	○	○
60	59.25	60.75									○	○	○	○	○	○	○	○
65	64.25	65.75										○	○	○	○	○	○	○
70	69.25	70.75											○	○	○	○	○	○
75	74.25	75.75												○	○	○	○	○
80	79.25	80.75													○	○	○	○
85	84.25	85.75														○	○	○
90	89.25	90.75															○	○
95	94.25	95.75																○
100	99.25	100.75																
120	119.25	120.75																
140	139.25	140.75																
160	159.25	160.75																
180	179.25	180.75																
200	199.25	200.75																

Notes (13) Applies to steel and martensitic stainless steel products.

(14) Lengths above 200 mm shall be subject to the agreement between the purchaser and the manufacturer.

Remarks : Lengths inside the bold lines are recommended.

Attached Table 6 Coiled, for light duty

Unit: mm

Nominal diameter			1.5	2	2.5	3	3.5	4	5	6	8
Before mounting d_1	Min.		1.62	2.13	2.65	3.15	3.67	4.2	5.2	6.25	8.3
	Max.		1.75	2.28	2.82	3.35	3.87	4.45	5.5	6.55	8.65
Before mounting d_2 (ref.)			1.4	1.9	2.4	2.9	3.4	3.9	4.85	5.85	7.8
Chamfer α			0.5	0.7	0.7	0.9	1	1.1	1.3	1.5	2
Thickness s			0.08	0.11	0.14	0.17	0.19	0.22	0.28	0.33	0.45
Shear strength ⁽¹⁵⁾ kN (min.)			0.8	1.5	2.3	3.3	4.5	5.7	9	13	23
			0.65	1.1	1.8	2.5	3.4	4.4	7	10	18
L											
Length	Min.	Max.									
4	3.75	4.25	○	○							
5	4.75	5.25	○	○	○						
6	5.75	6.25	○	○	○	○	○				
8	7.75	8.25	○	○	○	○	○	○			
10	9.75	10.25	○	○	○	○	○	○	○		
12	11.5	12.5	○	○	○	○	○	○	○		
14	13.5	14.5	○	○	○	○	○	○	○	○	
16	15.5	16.5	○	○	○	○	○	○	○	○	○
18	17.5	18.5	○	○	○	○	○	○	○	○	○
20	19.5	20.5	○	○	○	○	○	○	○	○	○
22	21.5	22.5	○	○	○	○	○	○	○	○	○
24	23.5	24.5	○	○	○	○	○	○	○	○	○
26	25.5	26.5		○	○	○	○	○	○	○	○
28	27.5	28.5		○	○	○	○	○	○	○	○
30	29.5	30.5		○	○	○	○	○	○	○	○
32	31.5	32.5		○	○	○	○	○	○	○	○
35	34.5	35.5		○	○	○	○	○	○	○	○
40	39.5	40.5		○	○	○	○	○	○	○	○
45	44.5	45.5			○	○	○	○	○	○	○
50	49.5	50.5				○	○	○	○	○	○
55	54.25	55.75						○	○	○	○
60	59.25	60.75						○	○	○	○
65	64.25	65.75								○	○
70	69.25	70.75								○	○
75	74.25	75.75								○	○
80	79.25	80.75									○
85	84.25	85.75									○
90	89.25	90.75									○
95	94.25	95.75									○
100	99.25	100.75									○
120	119.25	120.75									○

Note (15) Applies to steel and martensitic stainless steel products.

Remarks: Lengths inside the bold lines are recommended.

Annex (informative)
Comparison table between JIS and corresponding International Standards

JIS B 2808: 2005 <i>Spring pins</i>		(I) Requirements in JIS		(II) International Standard number		(III) Requirements in International Standards		(IV) Classification and details of technical deviation between JIS and the International Standards by clause		(V) Justification for the technical deviation and future measures	
Clause	Content	Clause	Content	Clause	Content	Clause	Content	Classification by clause	Detail of technical deviation		
1 Scope	Slotted spring pins, coiled spring pins and test methods are specified. Their contents are identical with ISO.	ISO 8752 ISO 13337 ISO 8748 ISO 8750 ISO 8751 ISO 8749	Heavy duty and light duty slotted spring pins, heavy duty, standard duty and light duty coiled spring pins and test methods are specified by six Standards.	1		While ISO specifies slotted spring pins, coiled spring pins and test methods by six separate Standards, JIS specifies them within a single Standard.	MOD/alteration	In JIS, the six ISO Standards were unified for the convenience in handling, without modification of the technical contents.			
	For slotted spring pins, nominal dimensions not specified in ISO and 14 types with nominal diameters of 1 mm to 13 mm which differ in tolerances are specified in attached table 2.	ISO 8752 ISO 13337	For slotted spring pins, 26 types with nominal diameters 1 mm to 50 mm and 24 light duty types 2 mm to 50 mm are specified.			Traditionally, JIS and ISO have differed in types and tolerances. In addition, JIS includes nominal diameters not specified in ISO (1.2 mm, 1.4 mm, 1.6 mm). They are specified in attached table 2.	MOD/addition	Since the nominal diameters and the tolerances specified in attached table 2 are frequently used, their usage will be investigated again by the next JIS revision to examine their unification. Based on the result, a proposal will be submitted to ISO.			

(I) Requirements in JIS		(II) International Standard number	(III) Requirements in International Standards		(IV) Classification and details of technical deviation between JIS and the International Standards by clause		(V) Justification for the technical deviation and future measures
Clause	Content		Clause	Content	Classification by clause	Detail of technical deviation	
1 Scope (concluded)	For coiled spring pins, heavy duty type, standard duty type and light duty type are specified.	ISO 8748 ISO 8750 ISO 8751	—	For coiled spring pins, 14 heavy duty types with nominal diameters 1.5 mm to 20 mm, 17 standard duty types 0.8 mm to 20 mm and 9 light duty types 1.5 mm to 8 mm are specified.	IDT	—	—
2 Normative references	Four Standards are referred to: ① JIS B 0401-1 ② JIS B 1044 ③ JIS B 1091 ④ JIS Z 2244 ⑤ —		2	ISO 286-1 ISO 4042 ISO 3269 — ISO 8749	IDT IDT IDT MOD/ addition IDT	Contents were specified as 7.1 of the text.	Hardness test was added considering the convenience in handling. JIS is equivalent to ISO.
3 Classification	Three types of slotted spring pins, heavy duty (GH), standard duty (GS) and light duty (GL), are specified. Three types of coiled spring pins, heavy duty (CH), standard duty (CS) and light duty (CL), are specified.	ISO 8752 ISO 13337 ISO 8748 ISO 8750 ISO 8751	3	Two types of slotted spring pins, heavy duty and light duty, are specified. Three types of coiled spring pins, heavy duty, standard duty and light duty, are specified.	MOD/ addition	Standard duty type (GS) which has been adopted in JIS and used traditionally was added.	Since this type has been traditionally widely used in Japan, submission of proposal is being studied.

(I) Requirements in JIS		(II) International Standard number	(III) Requirements in International Standards		(IV) Classification and details of technical deviation between JIS and the International Standards by clause		(V) Justification for the technical deviation and future measures
Clause	Content		Clause	Content	Classification by clause	Detail of technical deviation	
4 Shapes and dimensions	Traditionally, JIS specified two types of chamfering, both chamfered and single chamfered, and permitted the supplier, as in ISO, to adopt the single chamfered for these 10 mm or greater in nominal diameter. In this revision, to clearly distinguish the type, type symbols of single chamfered (Type V) and both chamfered (Type W) were defined.		4.2	—	MOD/addition	Type symbols were defined to clearly specify the type.	Type symbols were added for the convenience in handling. Submission of proposal is being studied.
5 Application		ISO 8752 ISO 13337 ISO 8748 ISO 8750 ISO 8751	5	—	IDT	—	—
6 Quality	Materials are specified by their names and the chemical compositions.	ISO 8752 ISO 13337 ISO 8748 ISO 8750 ISO 8751	6	—	IDT	—	—

(I) Requirements in JIS		(II) International Standard number		(III) Requirements in International Standards		(IV) Classification and details of technical deviation between JIS and the International Standards by clause		(V) Justification for the technical deviation and future measures
Clause	Content	Clause	Content	Classification by clause	Detail of technical deviation			
6 Quality (concluded)	Hardness of slotted and coiled spring pins of hardened and tempered or austempered carbon steel and silicon manganese steel is specified to 420 HV30 to 520 HV30. Hardness of coiled spring pins of hardened and tempered martensitic stainless steel is specified to 440 HV30 to 560 HV30.	ISO 8752 ISO 19397 ISO 8748 ISO 8750 ISO 8751	6 For slotted spring pins, hardness is specified to 420 HV30 to 520 HV30 for hardened and tempered carbon steel, to 500 HV30 to 560 HV30 for austempered carbon steel, and 420 HV30 to 560 HV30 for hardened and tempered silicon manganese steel. For coiled spring pins, hardness is specified to 420 HV30 to 545 HV30 for hardened and tempered steel, to 460 HV30 to 560 HV30 for martensitic stainless steel.	MOD/alteration	ISO requires different hardness values depending on the material used and the treatment. JIS specifies the hardness of slotted and coiled spring pins to 420 HV30 to 520 HV30 independent of treatment, and the hardness of coiled martensitic stainless steel spring pins to 440 HV30 to 560 HV30, identical with the slotted spring pins.	Requirements of ISO for hardness of slotted spring pins of austempered carbon steel and of silicon manganese steel, and for coiled spring pins of hardened and tempered steel and of martensitic stainless steel are questionable (excessive hardness may easily cause breakage). A proposal will be submitted at the revision of ISO Standard.		
	For slotted spring pins, two types of slots are specified: Normal case and Type N.		Identical with JIS.	IDT	—	—		
	Surface finish		Identical with JIS.	IDT	—	—		
	Surface condition		Identical with JIS.	IDT	—	—		
	Shear strength test		Identical with JIS.	IDT	—	—		

(I) Requirements in JIS		(II) International Standard number	(III) Requirements in International Standards		(IV) Classification and details of technical deviation between JIS and the International Standards by clause		(V) Justification for the technical deviation and future measures
Clause	Content		Clause	Content	Classification by clause	Detail of technical deviation	
7 Test methods		ISO 8749	7	Shear strength test is specified.	MOD/addition	Hardness test was added. In the shear strength test, spring pins 25 mm or greater in nominal diameter were specified to be tested as agreed between the purchaser and the manufacturer. Figure 3 was modified for ease of understanding.	Hardness test was added considering the convenience in handling. A proposal will be submitted to ISO.
8 Designation of products	The number or the title of this Standard, nominal diameter, length, type, type symbol representing the end chamfer and material symbol are specified.	ISO 8752 ISO 13337 ISO 8748 ISO 8750 ISO 8751	8		IDT		

(I) Requirements in JIS		(II) International Standard number	(III) Requirements in International Standards		(IV) Classification and details of technical deviation between JIS and the International Standards by clause		(V) Justification for the technical deviation and future measures
Clause	Content	Clause	Content	Classification by clause	Detail of technical deviation		
9 Marking	Marking of the title of this Standard, nominal diameter, length, type, type symbol of end chamfer, material, volume, serial number and the manufacturer's name or registered trade mark are specified.	9	—	MOD/addition	Not specified in ISO.	This clause is required for harmonizing with other JIS. A proposal will be submitted to ISO.	

Designated degree of correspondence between JIS and International Standards: MOD

Remarks 1 Symbols in sub-columns of classification by clause in the above table indicate as follows:

- IDT: Identical in technical contents.
 - MOD/addition: Adds specification item(s) or content(s) which are not included in International Standard.
 - MOD/alteration: Alters the specification content(s) which are included in International Standard.
- 2 Symbol in column of designated degree of correspondence between JIS and International Standards in the above table indicates as follows:
- MOD: Modifies International Standards.

Errata for JIS (English edition) are printed in *Standardization Journal*, published monthly by the Japanese Standards Association, and also provided to subscribers of JIS (English edition) in *Monthly Information*.

Errata will be provided upon request, please contact:
Standardization Promotion Department, Japanese Standards Association
4-1-24, Akasaka, Minato-ku, Tokyo, 107-8440 JAPAN
TEL. 03-3583-8002 FAX. 03-3583-0462